

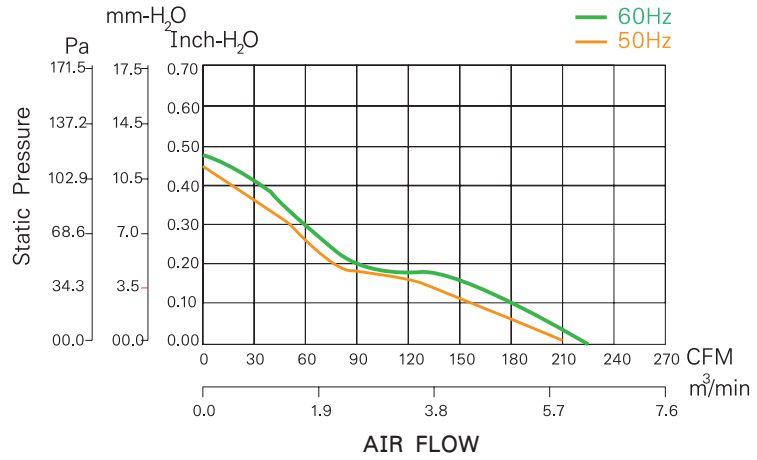

### GENERAL SPECIFICATIONS

- FRAME SIZE : 172x150x55mm.
- HOUSING : MAGNESIUM ALLOY
- IMPELLER : MAGNESIUM ALLOY
- BEARING TYPE : BALL BEARING
- OPERATION TEMPERATURE : -10°C - +100°C
- RELATIVE HUMIDITY : 35% ~ 85%
- MOTOR : **SQUIRREL CAGE MOTOR**  
**THERMALLY PROTECTED**



WB1725H5MS...

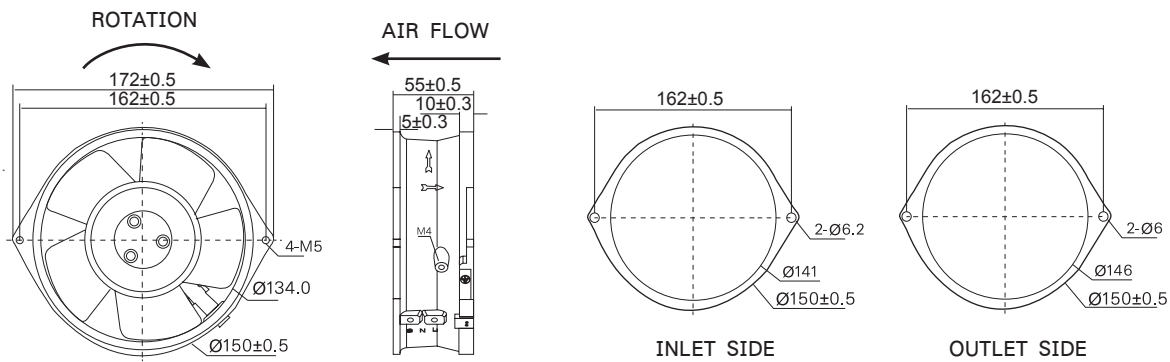

\* หน่วย : mm. \*

MODEL	VOLTAGE (VAC)	FREQ (HZ)	CURRENT (A)	POWER (W)	SPEED (RPM)	NOISE (DBA)	AIRFLOW (CFM)
WB1725H5MS-A1L-G(H.T.R.100)IP55	110-120	50/60	0.48/0.44	45/42	2600/2900	58/60	210/230
WB1725H5MS-A2L-G(H.T.R.100)IP55	220-240	50/60	0.28/0.25	45/42	2600/2900	58/60	210/230

**อุปกรณ์เสริม**

\*ดูรายละเอียดหน้า 18 \*



**อุปกรณ์ที่ใช้ร่วมกัน**

\*ดูรายละเอียดหน้า 70 \*

**Section 1**

