

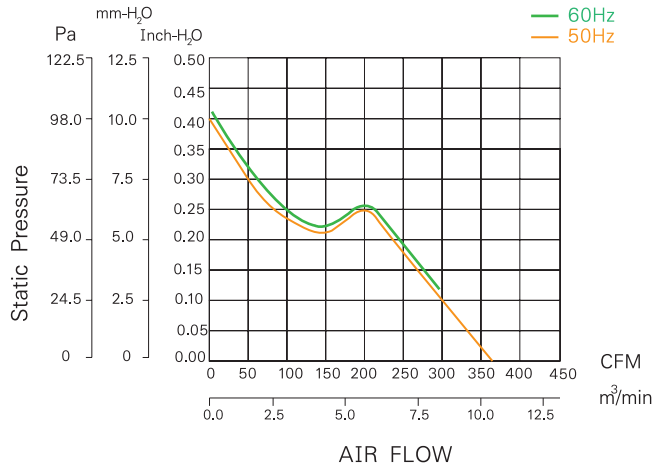

### GENERAL SPECIFICATIONS

- FRAME SIZE : 222x60mm.
- HOUSING : ALUMINIUM ALLOY
- IMPELLER : MAGNEIUM ALLOY
- BEARING TYPE : BALL BEARING
- OPERATION TEMPERATURE : -10°C - +100°C
- RELATIVE HUMIDITY : 35% ~ 85%
- MOTOR : **SQUIRREL CAGE MOTOR**  
**THERMALLY PROTECTED**



WB2206H5MS...

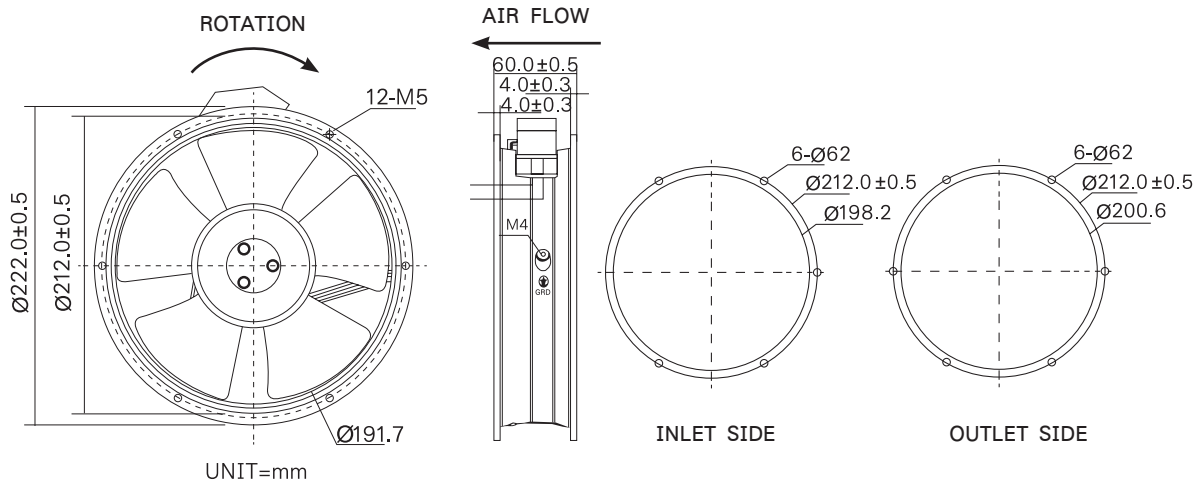

MODEL	VOLTAGE (VAC)	FREQ (HZ)	CURRENT (A)	POWER (W)	SPEED (RPM)	NOISE (DBA)	AIRFLOW (CFM)
WB2206H5MS-A2L-G(H.T.R.100) IP55	220-240	50/60	0.29/0.27	53/53	2500/2500	60/60	360/360

**อุปกรณ์เสริม**

\*ดูรายละเอียดหน้า 24 \*



**อุปกรณ์ที่ใช้ร่วมกัน**

\*ดูรายละเอียดหน้า 70 \*

**Section 1**

